

# ARMA - JNB

## Indoor Led Power Supply

ARMALED AYDINLATMA ELEMANLARI  
İMALAT SANAYİ VE TİCARET. A.Ş.  
Ümraniye İstanbul Türkiye  
Tel: +90 216 365 4646  
E-mail: info@armaled.com.tr www.armaled.com.tr



Model: JLV-12300KS(12V) Size: 224\*68\*41mm  
JLV-24300KS(24V)



### Brief Information

Thin &  
Slim Shape

# 300W

### Power Supply (C.V.)

Model JLV-12300KS / JLV-24300KS

Input 200-250V AC

Output 12VDC 25A 300W / 24VDC 12.5A 300W

### Product Features

- Compact size, easy for installation
- High transfer efficiency
- Endurable & stable quality
- 100% full loading, 100% burn-in tested
- Overload/short circuit protection

## MAIN ELECTRICAL DATA

### AC Input

Input Voltage	200-250V
Input Frequency	50/60Hz
Efficiency (Typ.)	84%
Input Current	230V: 2.3A max.
Inrush Current	40A
Leakage Current	3mA/120VAC

### DC Output

Output Voltage	12V	24V
Rated Current	25A	12.5A
Rated Power	300W	300W
Ripple & Noise (Max.)	<200mVp-p	<200mVp-p
Setup, Rise Time	1500ms/230VAC	1500ms/230VAC
Line Regulation	1%	1%
Load Regulation	1%	1%

## Service Environment

Working Temp.	-30°C~60°C
Working Humidity	20~90%RH
Storage Temp.	-40°C~80°C
Storage Humidity	10~95%RH

## Protection

Overload	Yes, cut-off activates while overload 5~25% Recovery after load reduces
Short Circuit	Yes, hiccup mode, recovers automatically after fault condition is removed

## Safety

Safety Standard	EN 61347-2-13
Withstand Voltage	I/P-O/P: 3KVAC I/P-GND: 1.5KVAC O/P-GND: 0.5KVAC
Isolation Resistance	I/P-O/P: >100M Ohms / 500VDC /25°C / 70%RH

## Packaging Information

Product Dimension	224*68*41mm
Products Net Weight	480G
PCS/Carton(QTY)	30 PCS
Master Carton Size	46*25*26cm
G. Weight/ Carton	16KG

### Installation Tips:

- Please identify the power supply's input and output before installation.
- Ensure correct output + & - wire connection.  
Power on after wire connection is done.
- To avoid voltage drop and loading capacity wasting on the output extension wire, please install the power supply to the loading as near as possible, if must use long extension wires, thicker wires and less loading wattage is required.
- The power supply to be installed at good ventilation and cooling environment.

## Physical Drawing

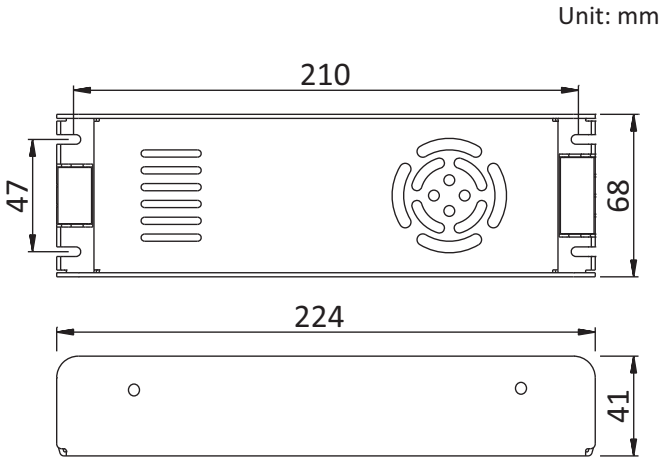

### Brief Information

Thin & Slim Shape

## 300W

Power Supply (C.V.)

Model JLV-12300KS / JLV-24300KS

Input 200-250V AC

Output 12VDC 25A 300W / 24VDC 12.5A 300W

Input & Output:

9500-7P Screw Terminals With Cover  
 inflaming retarding

Housing: Aluminium

## Block Diagram

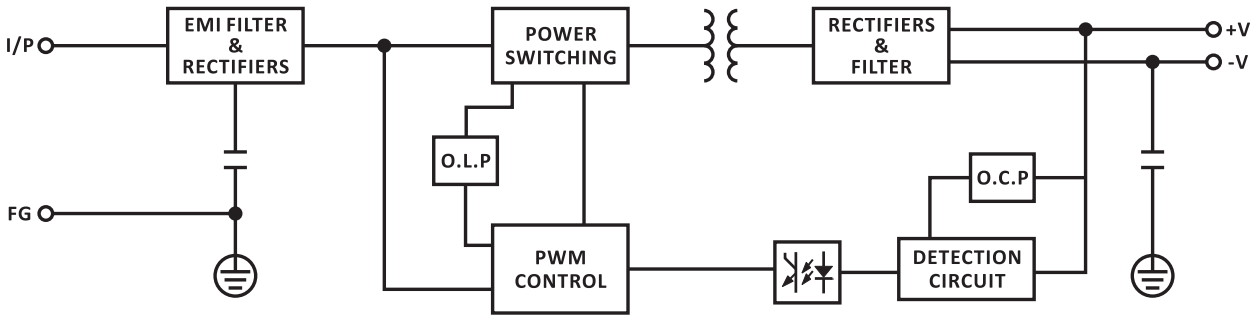

## Derating Curve

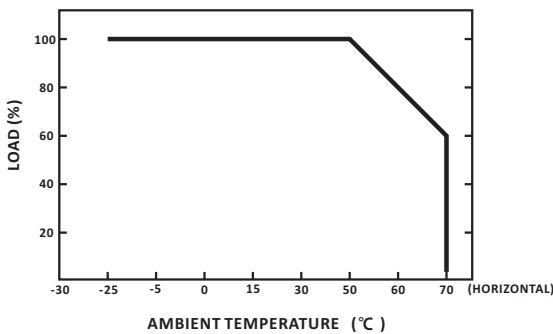

## Static Characteristics

